

BEAMFORMERS

TECHNICAL FEATURE

Beamformers are complex networks used to precisely control the phase and amplitude of RF energy passing through them. They are typically used in two complementary modes.

1. In RF transmitting systems such as radars, beamformers are employed between the RF signal source and the antenna radiating elements to “shape” The resulting radiated electromagnetic field in terms of its instantaneous field intensity in three dimensional space. The result is to “illuminate” a target or region of space with a precisely contoured beam’ of RF energy whose characteristics are known and to varying degrees can be controlled.
2. In receiving systems, beamformers are employed between the antenna arrays and the receiver to affect (shape) the relative spatial sensitivity of the system to RF signals originating in its field of view. The result is to effectively “focus” the receive system on a specific target or region of space.

Beamformer configurations vary widely from just a few basic building blocks up to tens of thousands of them depending on system performance requirements. Nevertheless, it will be shown that just a few building blocks can be combined in a few ways to meet even complex performance demands requiring thousands of’ replications of these basic building blocks.

There are two basic ways to shape an RF beam.

1. Passive elements
2. Active elements

The simplest beam forming method uses passive reflectors or parasitic elements to affect the near field region surrounding the radiating element. Conductive surfaces shaped into carefully planned geometric shapes such as paraboloids are used to create a pattern of constructive and destructive interference in the vicinity of the radiating element. When properly designed and implemented. The result is a precisely shaped beam of

RF energy focused in the desired direction with a shape and extent tailored to the application.

Antennas based on parabolic reflectors have found use at frequencies as low as 45 MHz in very large systems. However as a practical matter, parabolic antennas find their greatest use in wavelengths less than 1 meter; above 300 MHz.

Additionally, below about 10 Hz, arrangements of linear parasitic elements in planar arrays are used extensively to form carefully contoured beam patterns.

Using passive antenna elements such as paraboloid or linear parasitic reflectors as beamformers has the advantage of simplicity and low cost. However, die disadvantages are many. For example, due to the massive structure involved, arrays based on passive reflectors cannot move as rapidly as may required in systems that must track rapidly moving objects or must track many objects “simultaneously” by quickly moving the beam from one target to another. Even when the antenna can be made small and of lightweight materials for use on satellites, rapidly moving an antenna array to focus on diverse regions in sequence would impart highly undesirable momentum to the overall spacecraft resulting in an unstable platform requiring expensive dampening provisions.

Active elements accomplish Beamforming by substituting actively radiating antenna elements for passive ones to create the desired field. Precisely controlled RF currents are fed to the active antenna elements which create the desired beam shape from the controlled constructive and destructive interference patterns established in the near-field region of the array. Thus, there is no need to physically move the antenna to focus the beam on various targets. The beam can be moved arbitrarily. Moreover, the shape or The resulting beam can be dynamically altered from a broad “floodlight” illumination of a region to a “spotlight” small beam focused closely on a target of interest. The ability to dynamically alter the shape of a radar team is of great importance in tracking missiles and satellites.

BEAMFORMERS

As mentioned above, “beamformers” work by carefully controlling the amplitude and phase of RF energy conveyed to the radiating elements of an antenna array. Manipulating the amplitude and phase of the RF energy can be accomplished at various points in the path between, RF signal generation and its ultimate radiation as an RF field. However, maintaining a precise phase and amplitude relationship through an arbitrary number of active stages is difficult. When system requirements include a broad range of frequencies as well, the technical challenges mount.

As a result, standard practice is to use passive networks operating at both the transmit and receive frequencies.

An added advantage of this approach is that passive networks can be built to be very rugged, reliable and electrically stable under the harshest environmental conditions. Elements commonly used to make beamformers are quadrature couplers, hybrid junctions, phase shifters and power dividers.

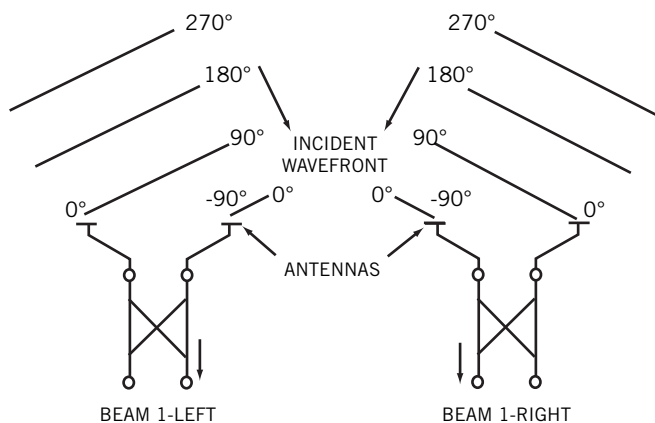

Figure 1: Simple Beamformer Using Quadrature Coupler

Figure 1 illustrates a simple beamformer comprising a simple antenna array connected to a quadrature coupler. In the quadrature coupler, “in-phase” input signals combine in output A and cancel in output B. Signals separated by 90° will combine in output B and cancel in output A. Therefore, a wavefront arriving from the left arrives at the left antenna prior to arriving at the right antenna. The difference is 90° . When the energy captured

by the two antennas is combined in the quadrature coupler, it is routed to just one output of the quadrature coupler. This is referred to as a beam left signal. The converse situation can be seen for a wavefront arriving from the right. Both examples of course depend on proper antenna element spacing for the frequency of interest.

If a 180° hybrid junction had been used in Figure 1 in place of the quadrature coupler, the two-element array would respond to arriving wavefronts arriving along a line between the two antenna elements and would comprise an end-fire beam.

A simple example of a beamformer is a quadrupole which divides a single signal input into four outputs of equal amplitude but differing in phase by, 0° , 90° , 180° and 270° . This basic network is shown in Figure 2.

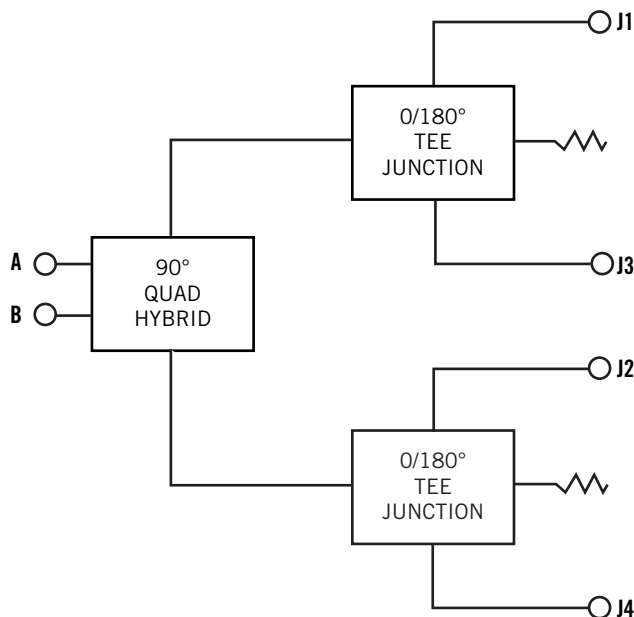

Figure 2: Quadrupole Network Schematic

Figure 3 shows an actual quadrupole unit. When used in conjunction with specialized receivers, beamformer networks can identify the location of an RF energy source. Moreover, when interfaced with suitable transducers, beamformers can be used in acoustic source location devices related to sonar. Thus, beamformers are employed in an assortment of direction finding systems.

BEAMFORMERS

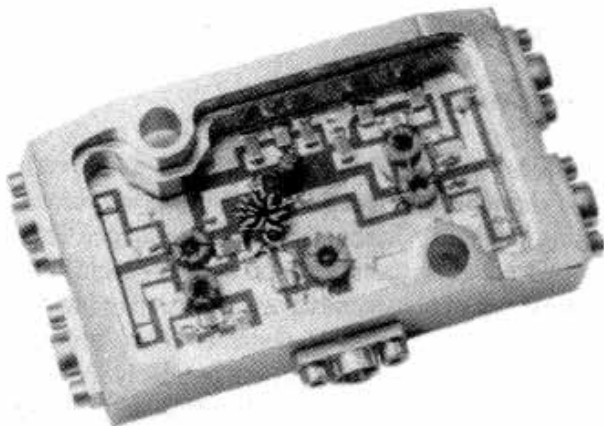

FIGURE 3: QUADRAPOLE NETWORK IN SUBMARINE PERISCOPE ANTENNA APPLICATION

Perhaps the most common application of quadrupole networks is to provide proper phasing for circularly polarized antenna feeds. By switching the input used, the “sense” of the antenna can be switched from right hand circular (RHC) to left hand circular (LHC) polarization.

A slightly more complex beamforming network is the four element beamforming matrix as illustrated in Figure 4. This configuration is created by taking the outputs from a pair of two beam matrices (i.e. two quadrature couplers) and feeding the outputs to a second level of hybrid junctions. In this case it is necessary to insert fixed 45° phase shifters in two paths to achieve the phasing necessary for proper combining. This routes a signal originating from a single point in space to a particular output port of the matrix. In this way the precise three dimensional coordinates of the signal source can be identified. This information is particularly important in radar warning and similar systems where the precise location in three dimensional space is essential.

An eight element beamforming matrix, as shown in Figure 5, requires a total of 20 passive networks including fixed 22.5° and 67.5° phase shifters. At this level and beyond, however, important economies can be realized in reducing the number of passive networks required.

More complexity arises as the number of antenna elements increases and the number of matrix levels increases as might be required of a focused, multi-element system. The actual number rises in a binary

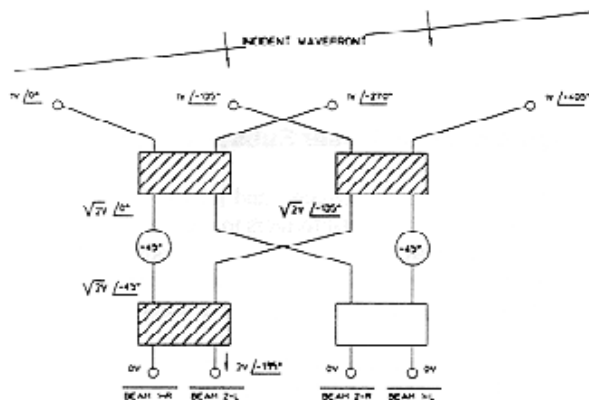
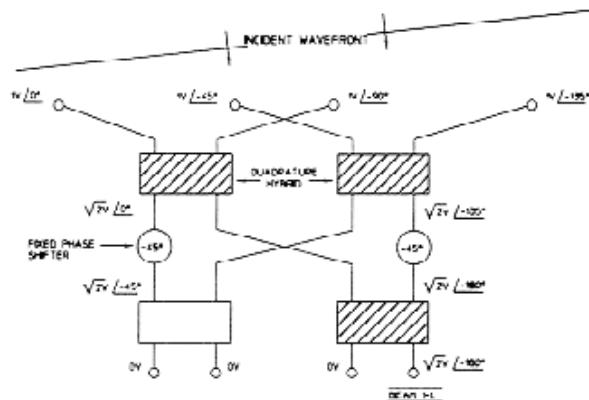

Figure 4: Four Element Beamforming Matrix

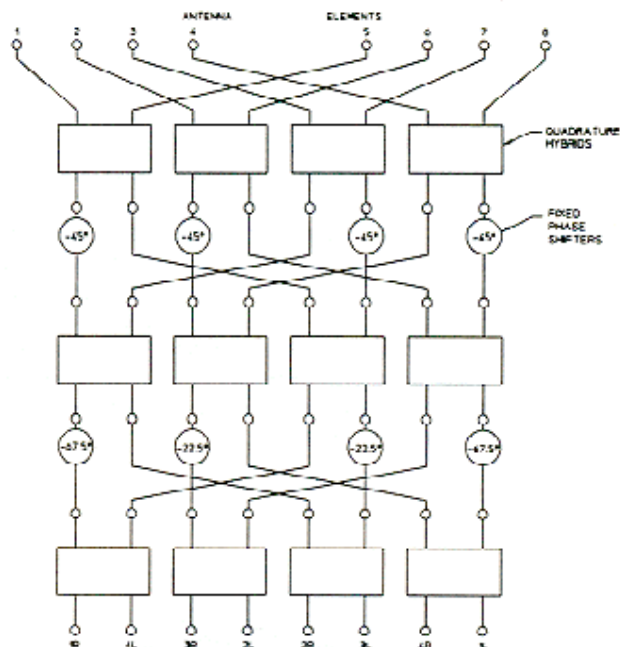

Figure 5: Eight Element Beamforming Matrix

BEAMFORMERS

fashion, i.e., 2, 4, 8, 16, 32, etc., as does the complexity and precision required of each passive network in the matrix.

Designing beamformers such as these requires a detailed knowledge of achievable performance characteristics of the four basic building blocks: 0° power dividers, quadrature couplers, hybrid junctions and fixed wideband phase shifters. The design challenge is a bit easier if the performance requirement is for a narrowband unit since phase errors can be corrected by adding line length. But as the required bandwidth is expanded, the need for highly stable and accurate components becomes progressively more critical.

Merrimac's experience in designing and producing precision passive networks in stripline, microstrip and lumped element technology is virtually unique. No other company combines the experience in the required design disciplines to produce units covering frequencies from 100 kHz to 40 GHz while exhibiting bandwidth ratios as high as 100:1.

In the lower frequencies, from 100 kHz to about 2 GHz, the preferred technology is lumped element. However, if significant power levels are involved, as in an over-the-horizon radar, air-line (suspended stripline) is usually the choice. Many such components were designed by Merrimac twenty or more years ago for lower frequency early warning radars.

To counter offensive missiles, aerospace systems were developed to identify the missile's precise trajectory and to afford earlier target acquisition. These defensive measures required accurate wideband beamformers operating from 500 MHz to 2 GHz or more. Using radar guidance, they had to be particularly rugged to survive wide variations in temperature as well as severe acceleration and vibration. Merrimac designed such a unit in the mid-1980's using a combination of lumped element and microstrip technologies. Well over 1000 of these Hi-Rel beamformers were built by Merrimac over the life of the program. Not a single failure has been reported. Figure 6 shows one of the units.

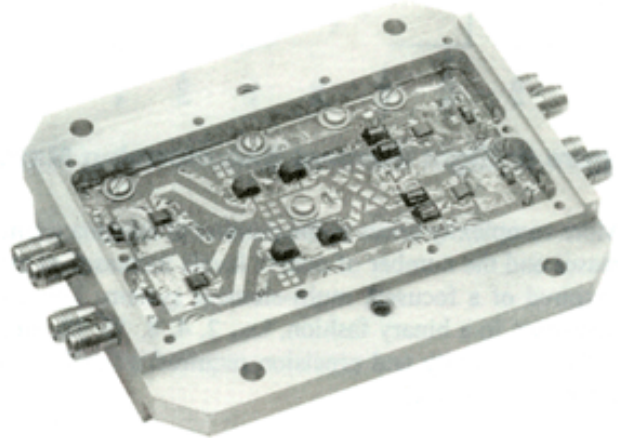

Figure 6: Airborne Warning System Beamformer

Beamformers do not always operate at the frequency of the radar. Occasionally they can operate at an intermediate frequency (I.F.). Where size is critical as in a missile, for example, beamformers may operate in the 50 to 100 MHz region and usually use lumped element designs. Figure 7 shows an example of such a unit built by Merrimac in very large quantities for a missile program.

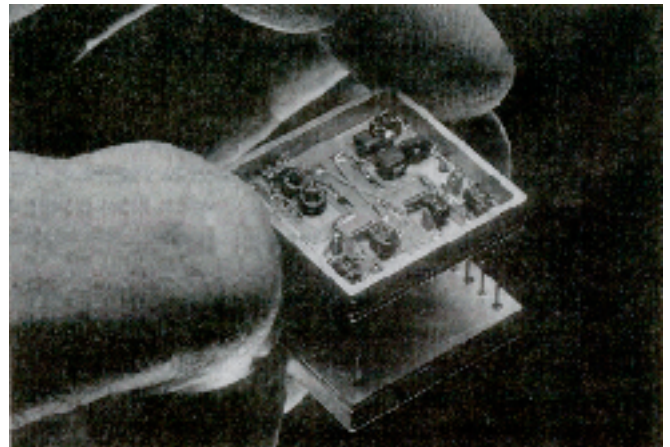

Figure 7: Missile Guidance Beamformer

Beamformers are also combined with other subsystems as shown in Figures 8 and 9. This subsystem is designed to maintain four input channels in a specific phase and amplitude relationship while the reference is switched in quadrature.

BEAMFORMERS

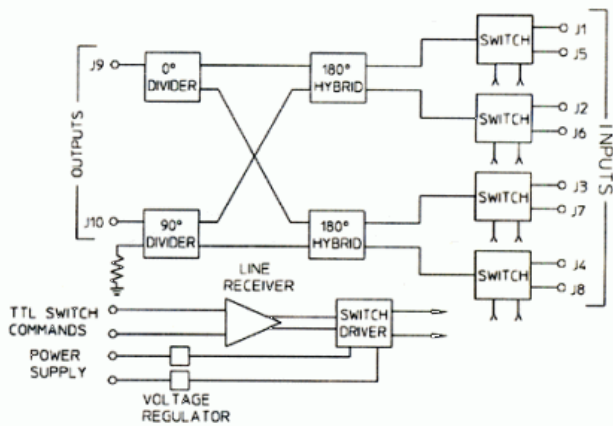

Figure 8: Beamformer Subsystem Schematic

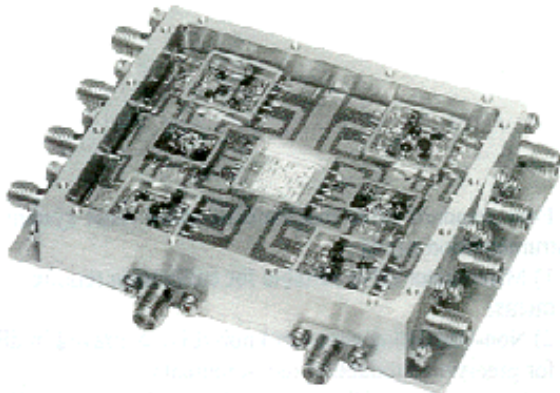

Figure 9: Beamformer Sub-System for Airborne Application

Military electronic intercept and related RF intelligence gathering systems use beamformers to precisely locate signal sources. They must be very broadband in order to detect all emissions in the range of interest. Usually systems are broken into discrete frequency bands to preserve accuracy.

When used in various electronic intelligence roles (e.g., ELINT, SIGINT and COMINT) analysis of the signal is often essential to success. Thus, very low distortion in the signal path is essential to success. An eight-input, sixteen-output beamformer meeting these criteria is shown in Figure 10.

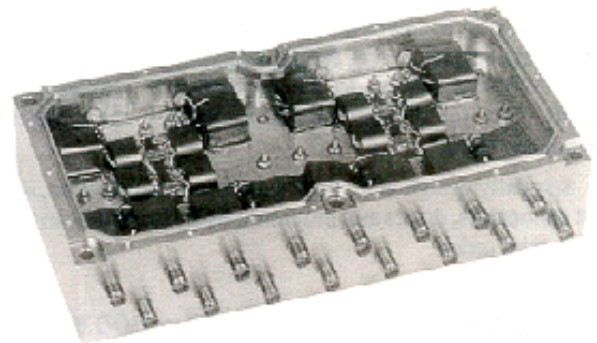

Figure 10: 0.5 to 110 MHz 16 Element Beamformer

This unit covers 500 kHz to 110 MHz with amplitude and phase accuracy to a fraction of a dB and a few degrees, respectively.

Large phased array antennas need to be fed from beamformers with an output for every element of the antenna. Such a beamformer undergoing final test is shown in Figure 11. Each of the 256 outputs is defined precisely in terms of phase and amplitude. This is a formidable task of calibration that would become impossible if accuracy is not designed-in from the start.



Figure 11: Large Phased Array Beamformer Undergoing Final Testing

BEAMFORMERS

A beamformer designed for a helicopter application is shown in Figure 12. This unit routes broadband microwave signals to different receivers for analysis.

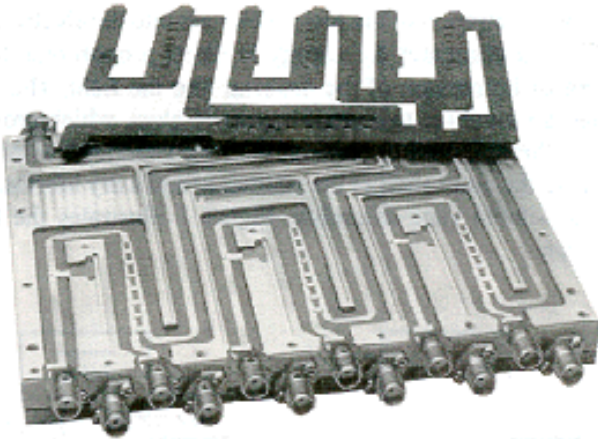

Figure 12: Helicopter Beamformer Application

Merrimac maintains a high level of expertise in beamformer design and manufacture. Meeting challenging technical performance specifications is our forte. Please consider this an invitation to present your challenge to Merrimac's cadre of beamformer experts.